

EN-Series - Valve Regulated Lead Acid Battery

EN540-2

SPECIFICATIONS		
Nominal voltage	2	V
10-hr rate Capacity to 10.8V at 20°C	540	Ah
10-min rate Constant Power to 1.6V/cell at 20°C	2400	Watts
DIMENSIONS		
Length	305 (±1)	mm
Width	210 (±1)	mm
Height	240 (±1)	mm
(height over terminals)	N/A	mm
Mass (typical)	35	kg
TERMINAL TYPE		
Threaded terminal - (M=Male or F=Female)	M8 (F)	mm
Torque	6 (±0.5)	Nm
OPERATING TEMPERATURE RANGE		
Storage (in fully charged condition)	-20°C to +50°C	
Charge	-15°C to +50°C	
Discharge	-20°C to +60°C	
STORAGE		
Capacity loss per month at 20°C (approx)	3	%
CASE MATERIAL		
Flame retardant	ABS (UL94:V0)	
CHARGE VOLTAGE		
Float charge voltage at 20°C	2.26 (±1%)	V
	2.26 (±1%)	V/cell
Float Charge voltage temperature correction factor (for variations from the standard 20°C)	-3	mV/cell/°C
Boost charge at 20°C	2.40 (±2%)	V
	2.40 (±2%)	V/cell
Boost Charge voltage temperature correction factor (for variations from the standard 20°C)	-4	mV/cell/°C
CHARGE CURRENT		
Float charge current limit	No limit	A
Boost charge current limit	135	A
MAXIMUM DISCHARGE CURRENT		
1 second	4500	A
1 minute	2880	A
SHORT-CIRCUIT CURRENT & INTERNAL RESISTANCE (according to EN IEC 60896-21)		
Internal resistance	1.71	mΩ
Short-Circuit current	4157	A
IMPEDANCE		
Measured at 1 kHz	0.4	mΩ
PERFORMANCE & CHARACTERISTICS		
Refer to the technical manual	EN	
DESIGN LIFE		
EUROBAT Classification: High Performance	-	
EUROBAT Classification: Long Life	12+	years
Yuasa design life @ 20°C	12	years
SAFETY		
Installation	Can be installed and operated in any orientation except permanently inverted	
Handles	Batteries must not be suspended by their handles (where fitted)	
Vent valves	Each cell is fitted with a low pressure release valve to allow gasses to escape and then reseal.	
Gas Release	VRLA Batteries release hydrogen gas which can form explosive mixtures in air. Do not place inside a sealed container	
Recycling	YUASA's VRLA batteries must be recycled at the end of life in accordance with local and national laws and regulations	



LAYOUT

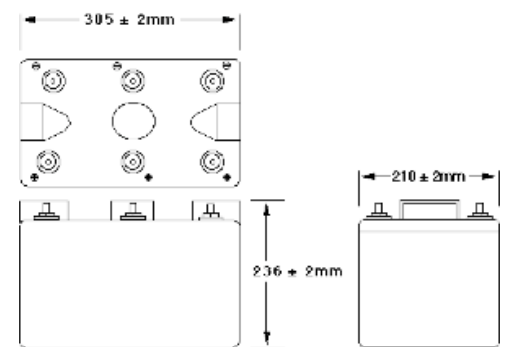

3RD PARTY CERTIFICATIONS

ISO 9001 - Quality Management Systems
 ISO 14001 - Environmental Management Systems
 EN 18001 - OHSAS Management Systems
 UNDERWRITERS LABORATORIES Inc.



STANDARDS

IEC61056
 IEC60896-21/22



ALL DATA IS SUBJECT TO CHANGE WITHOUT NOTICE
 Issue No.: V.2 / Issue Date: March 2011



YUASA BATTERY SALES
 UK LTD.
 Unit 13, Hunts Rise
 South Marston Industrial
 Estate
 SN3 4TG
 UK