

## EN-Series - Valve Regulated Lead Acid Battery

### EN160-4

SPECIFICATIONS		
Nominal voltage	4	V
10-hr rate Capacity to 10.8V at 20°C	163	Ah
10-min rate Constant Power to 1.6V/cell at 20°C	672	Watts
DIMENSIONS		
Length	206 (±2)	mm
Width	210 (±1)	mm
Height	240 (±1)	mm
(height over terminals)	N/A	mm
Mass (typical)	24.0	kg
TERMINAL TYPE		
Threaded terminal - ( M=Male or F=Female )	M8 (F)	mm
Torque	6 (±0.5)	Nm
OPERATING TEMPERATURE RANGE		
Storage (in fully charged condition)	-20°C to +50°C	
Charge	-15°C to +50°C	
Discharge	-20°C to +60°C	
STORAGE		
Capacity loss per month at 20°C (approx)	3	%
CASE MATERIAL		
Flame retardant	ABS (UL94:V0)	
CHARGE VOLTAGE		
Float charge voltage at 20°C	4.52 (±1%)	V
	2.26 (±1%)	V/cell
Float Charge voltage temperature correction factor (for variations from the standard 20°C)	-3	mV/cell/°C
Boost charge at 20°C	4.8 (±2%)	V
	2.40 (±2%)	V/cell
Boost Charge voltage temperature correction factor (for variations from the standard 20°C)	-4	mV/cell/°C
CHARGE CURRENT		
Float charge current limit	No limit	A
Boost charge current limit	40.75	A
MAXIMUM DISCHARGE CURRENT		
1 second	1500	A
1 minute	960	A
SHORT-CIRCUIT CURRENT & INTERNAL RESISTANCE		
<b>(according to EN IEC 60896-21)</b>		
Internal resistance		mΩ
Short-Circuit current	3009	A
IMPEDANCE		
Measured at 1 kHz	1.2	mΩ
PERFORMANCE & CHARACTERISTICS		
Refer to the technical manual	EN	
DESIGN LIFE		
EUROBAT Classification: High Performance	-	
EUROBAT Classification: Long Life	12+	years
Yuasa design life @ 20°C	12	years
SAFETY		
<b>Installation</b>	Can be installed and operated in any orientation except permanently inverted	
<b>Handles</b>	Batteries must not be suspended by their handles (where fitted)	
<b>Vent valves</b>	Each cell is fitted with a low pressure release valve to allow gasses to escape and then reseal.	
<b>Gas Release</b>	VRLA Batteries release hydrogen gas which can form explosive mixtures in air. Do not place inside a sealed container	
<b>Recycling</b>	YUASA's VRLA batteries must be recycled at the end of life in accordance with local and national laws and regulations	

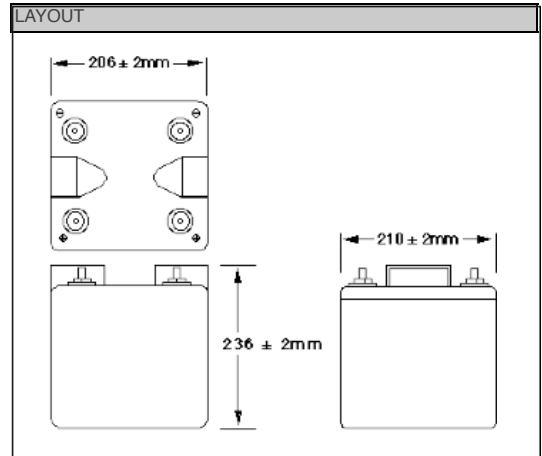

#### 3RD PARTY CERTIFICATIONS

ISO 9001 - Quality Management Systems  
 ISO 14001 - Environmental Management Systems  
 EN 18001 - OHSAS Management Systems  
 UNDERWRITERS LABORATORIES Inc.

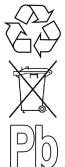

#### STANDARDS

IEC61056  
 IEC60896-21/22



ALL DATA IS SUBJECT TO CHANGE WITHOUT NOTICE  
 Issue No.: V.2 / Issue Date: March 2011



YUASA BATTERY SALES  
 UK LTD.  
 Unit 13, Hunts Rise  
 South Marston Industrial  
 Estate  
 SN3 4TG  
 UK